

ICON X

Metal
Earth

3D METAL MODEL KITS



Odporúčame vám navštíviť
www.metalearth.com/360/icx116
aby ste si pozreli dokončený model pred zostavením vlastného

METAL SHEET A

Časti, ktoré majú rovnakú farbu,
sú duplikáty

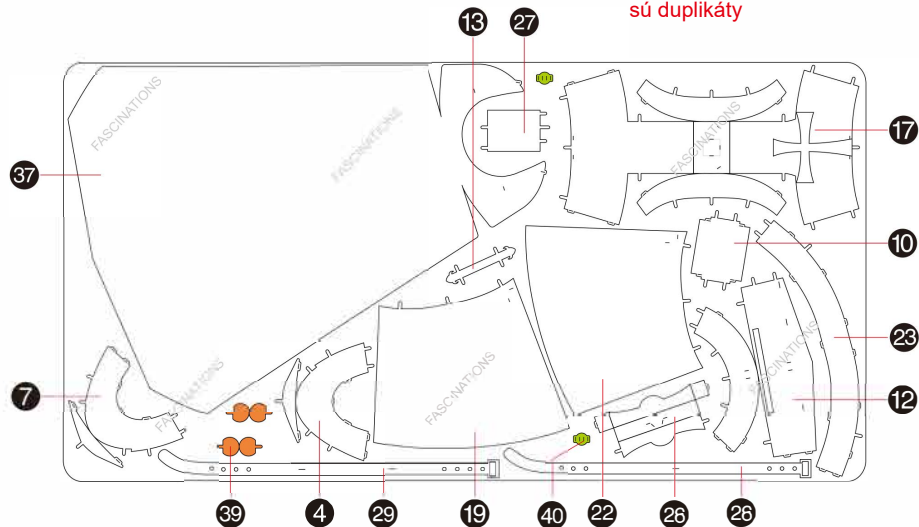

METAL SHEET B

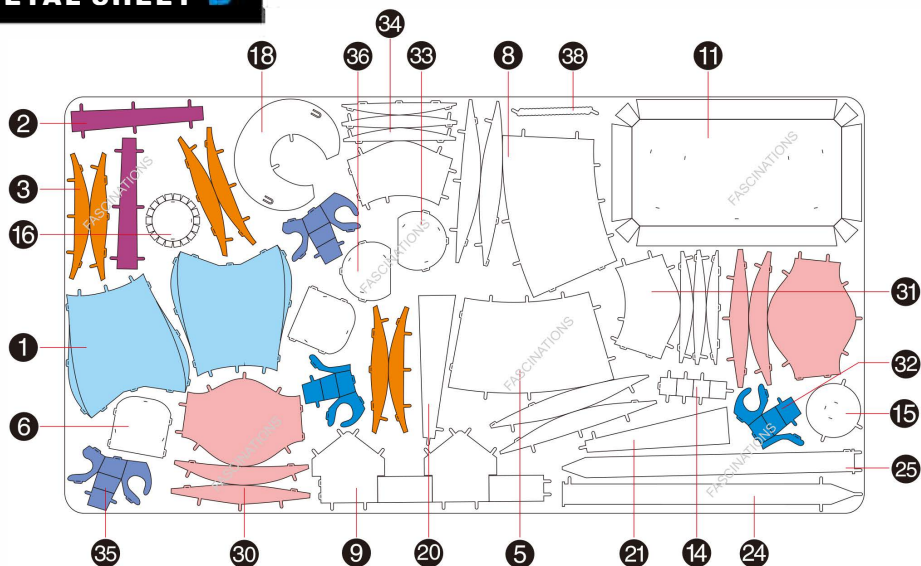

Aby ste zabránili možnému poraneniu ostrými hranami, po odstránení dielov opatrne zlikvidujte plechy.

Na stránke www.metalearth.com/360/icx116 si môžete pozrieť zväčšenú verziu tohto návodu.

ICX116



Templársky rytier



VYTVARAĽ NAJLEPŠIE PREPOJENIA

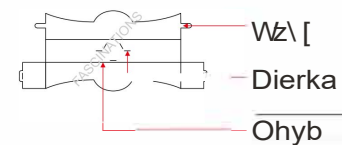

Legenda

- Gravírovaná/farebná strana
- Negravírovaná/strieborná strana
- Bod upozornenia
- Vložte uško a ohnite ho o 90 stupňov
- Vložte uško a otočte ho o 90 stupňov

Odporúčané náradie:

Nožnice na drôt: užitočné na vyberanie dielov z plechov.



Pinzeta alebo ihlové kliešte: užitočné na skladanie dielov, ohýbanie a krútenie ušíek.

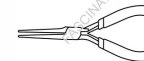
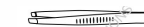

Tip pre montáž:

Ak je to potrebné, mierne skrúťte záložky, aby držali pohromade, potom ich rozviňte a ohnite nadol.

ASSEMBLY STEPS

Step 1

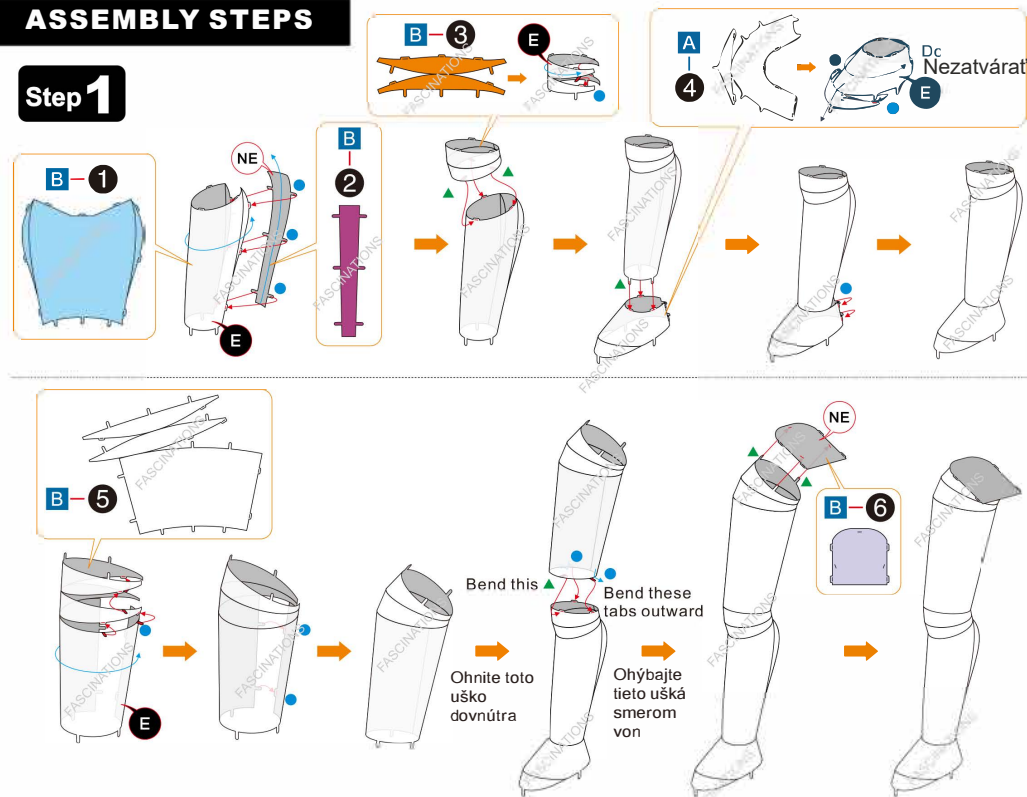

Step 2

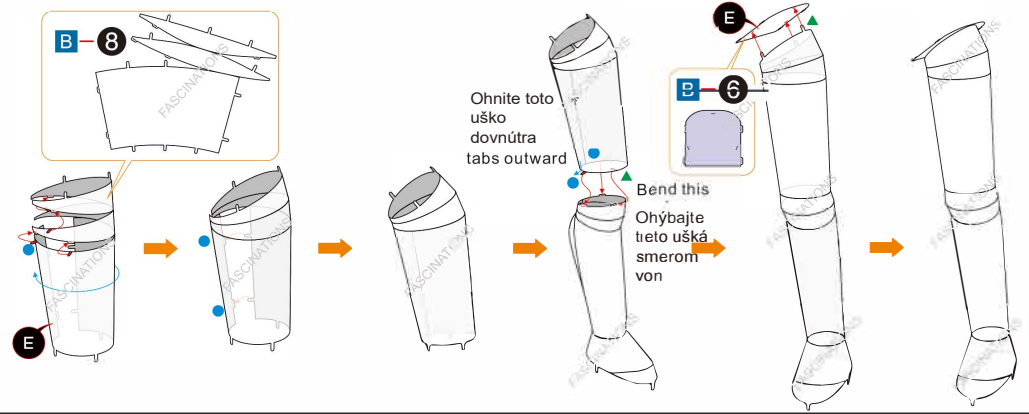
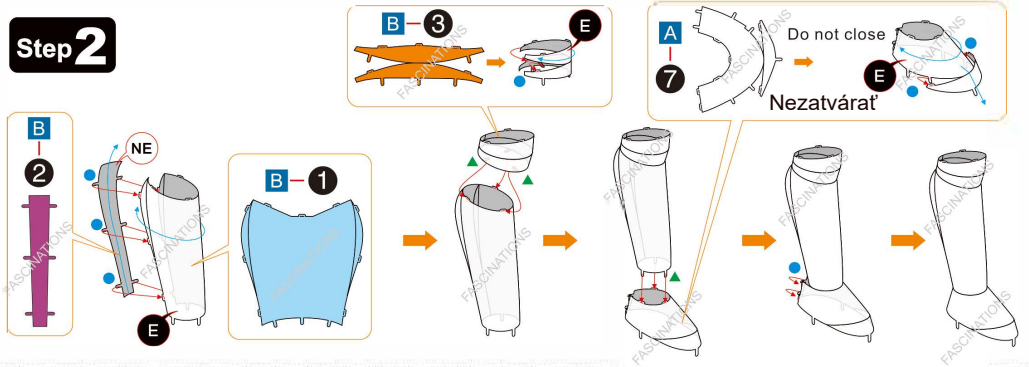

Step 3

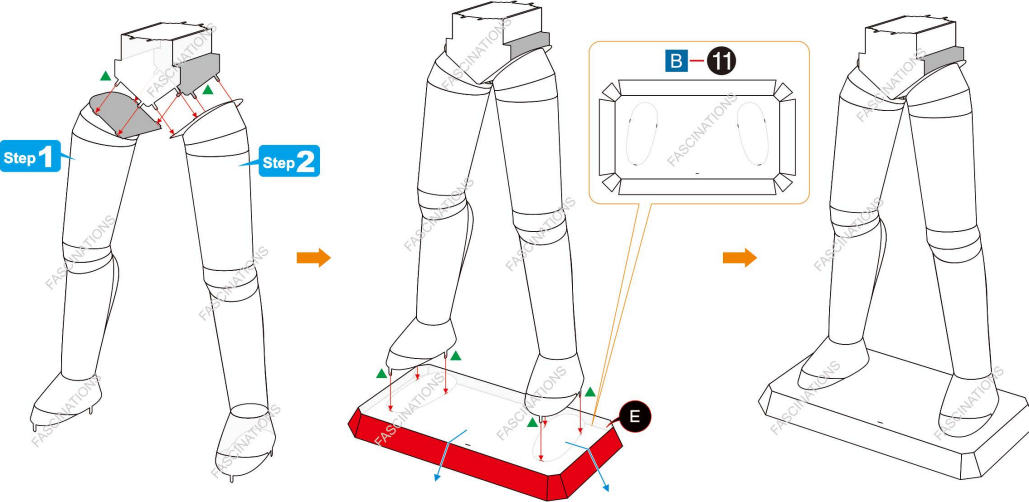
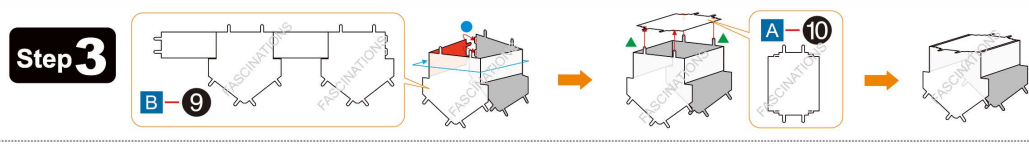

Step 4

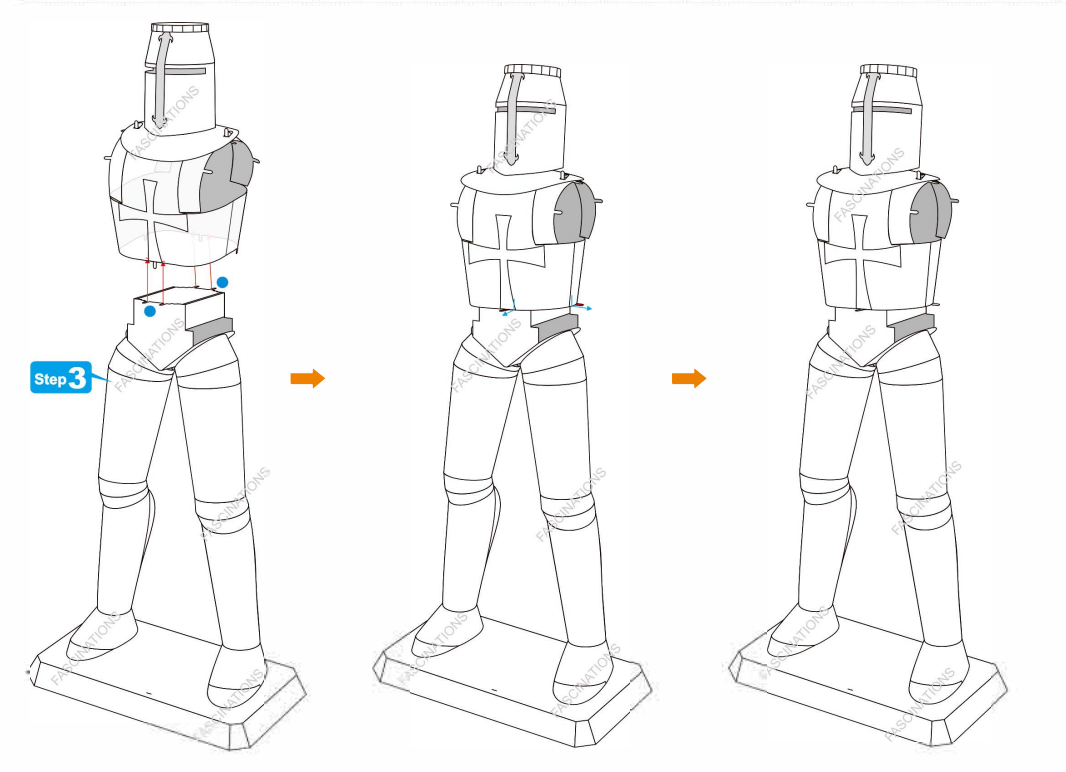
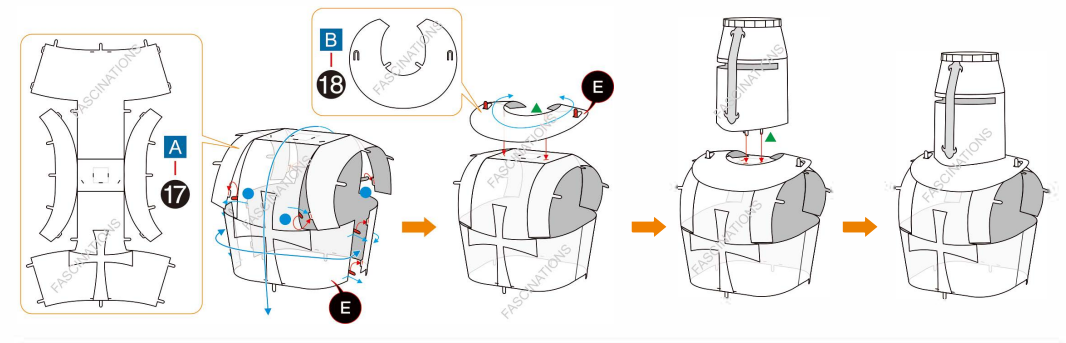
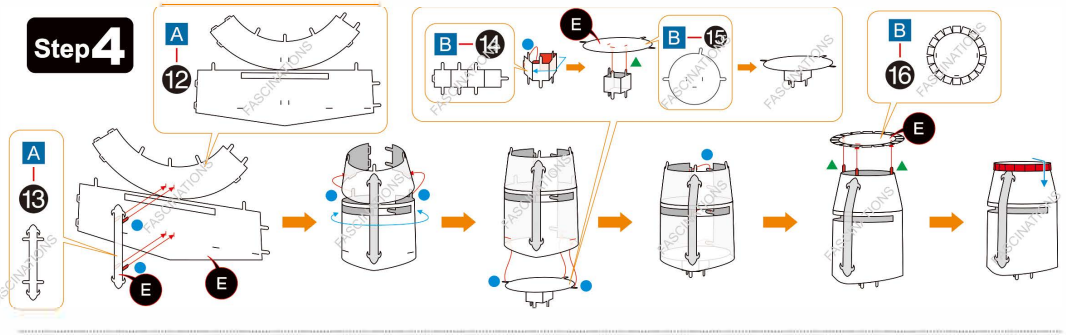

Step 5

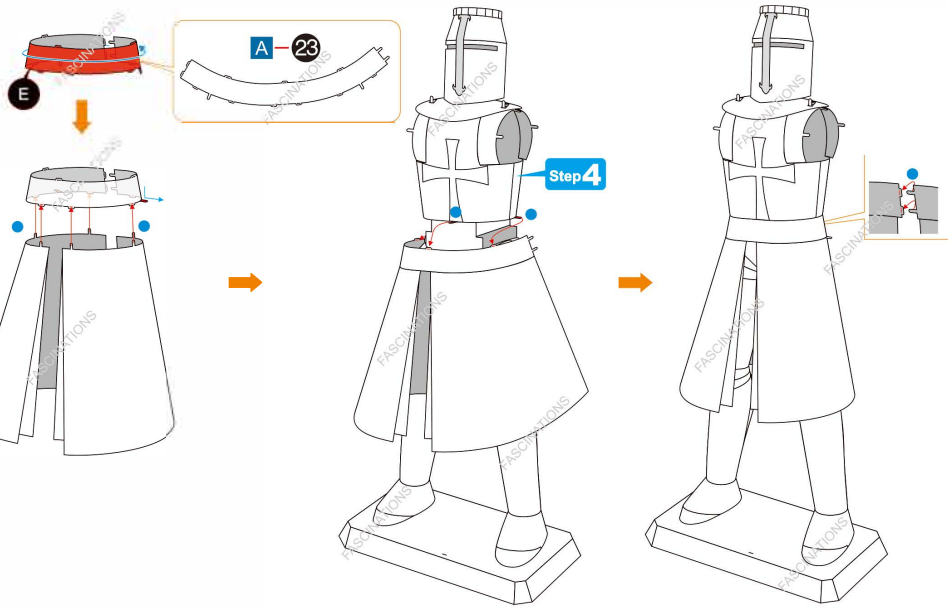
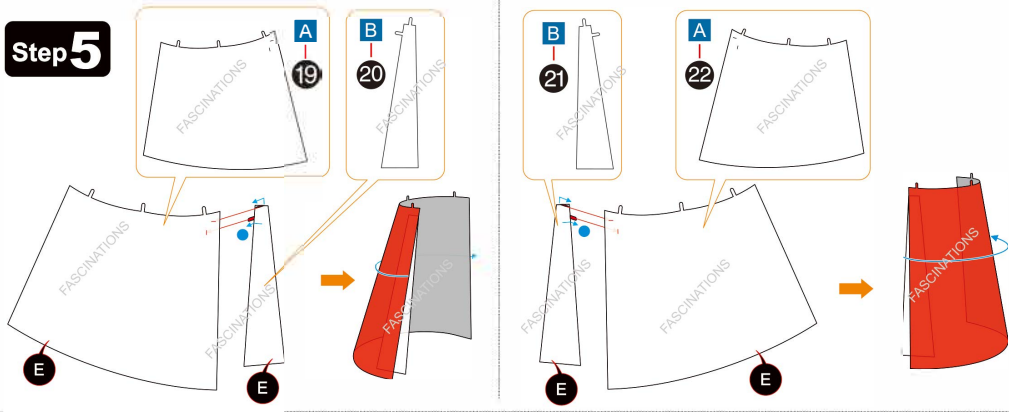

Step 6

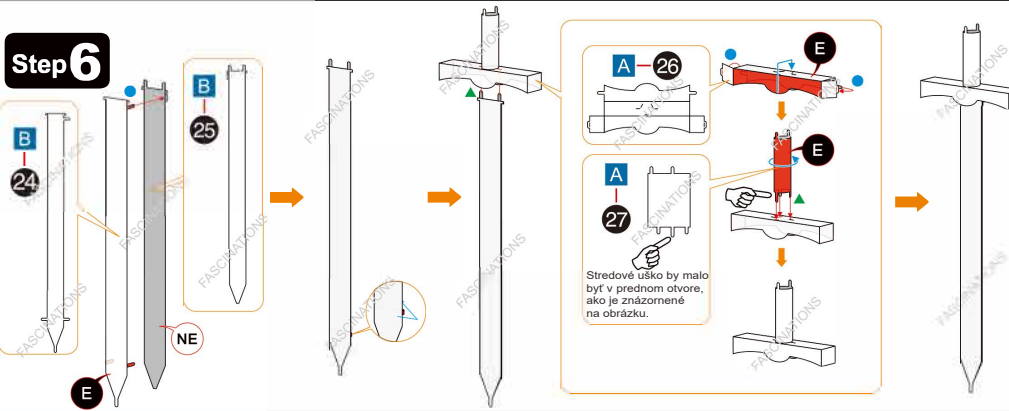

Step 7

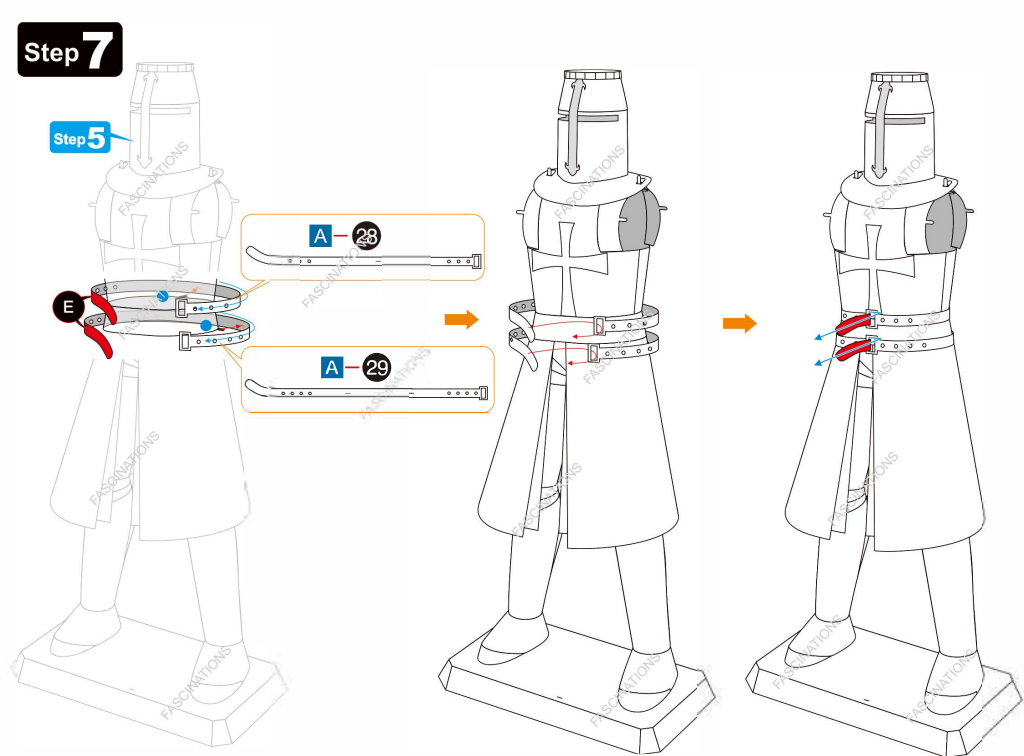

Step 8

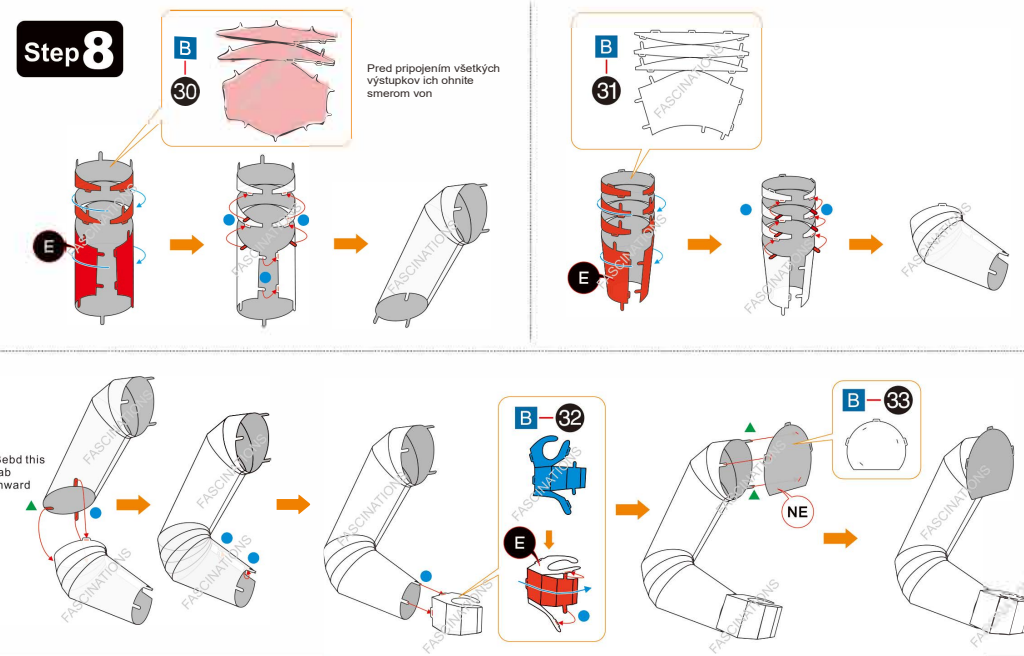

Step 9

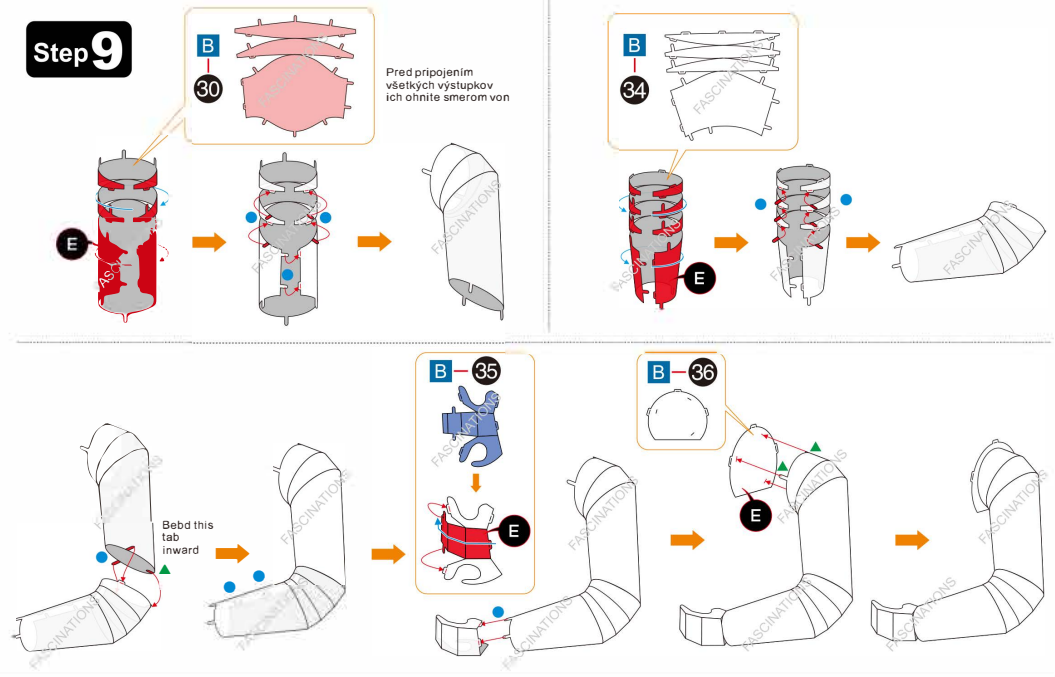

Step 11

Step 10

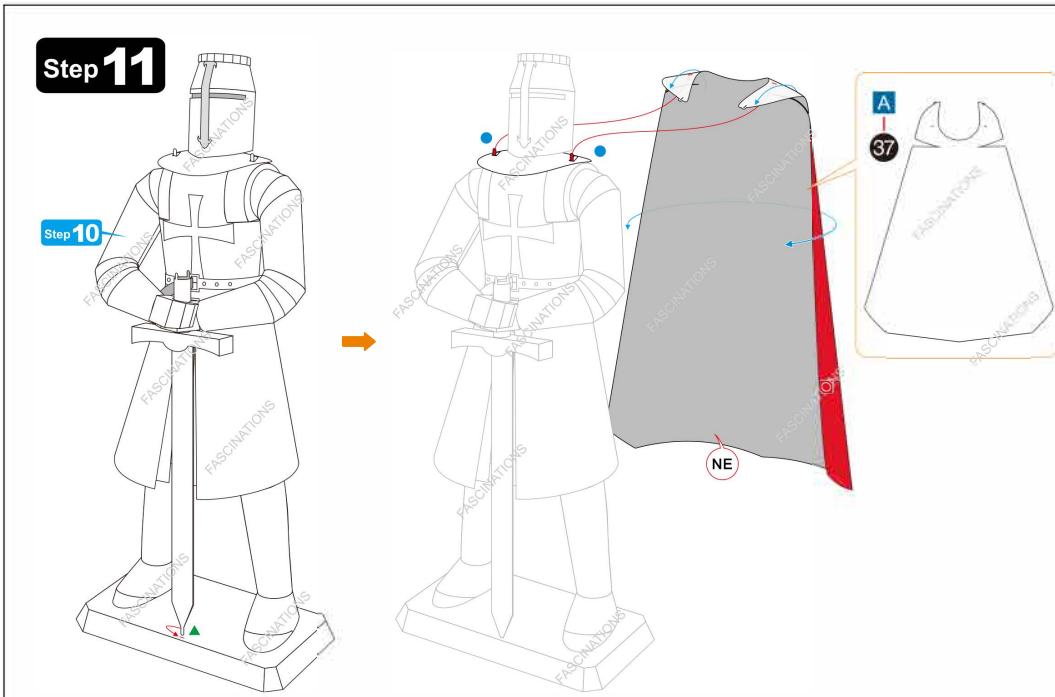

Step 10

